

Manufactured Since 1942 by: Apex Engineering Products Corporation

RYDLYME

World's Leading Biodegradable Descaler

Plastic Industry

RYDLYME dissolves water scale, lime, mud and rust deposits safely, quickly and effectively!

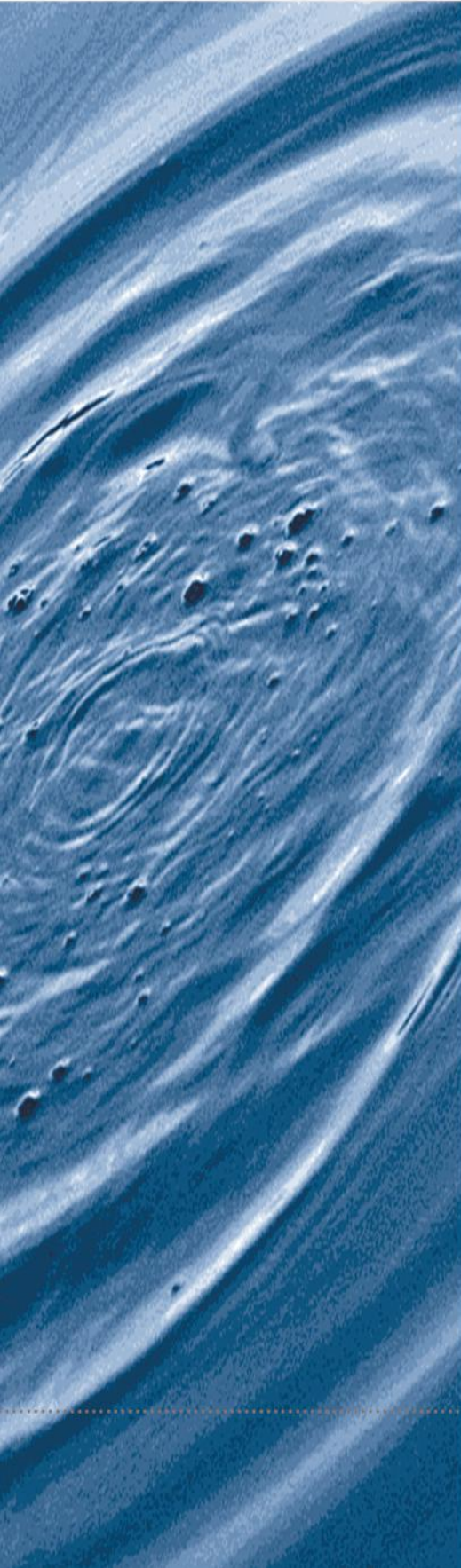

Before



After

*the solution to your
water scale problems*

RYDLYME and the Plastic Industry

The cooling process within plastic injection molding is very critical to the quality of the mold, and takes up about 50-75% of the total cycle time. Therefore, it is critical to maintain a clean, efficient cooling channel capable of removing heat at the required rates. Any deviation to that would result in an inconsistent mold quality from cycle to cycle.

When mineral deposits from the cooling water drop out and attach to cooling channel walls or heat exchanger tubes, a thermal barrier is created which significantly reduces heat transfer. The resulting uneven temperature of the mold surface (uneven shrinkage) results in parts with molded-in stresses, warped/twisted sections, sink marks, poor surface appearance and varying part dimensions from cycle to cycle.

RYDLYME is a revolutionary product designed to dissolve the toughest water scale, lime, mud, and rust deposits from virtually any piece of water-based equipment. This powerful, yet totally safe, liquid descaler is non-toxic, non-injurious, non-flammable, non-hazardous, non-corrosive, and *biodegradable*; so **RYDLYME** will not harm your personnel, equipment, or our environment!

RYDLYME can be utilized to clean the whole cooling circuit through the cooling tower (see *drawing next page*), or it can be used to clean an isolated piece of equipment using a secondary pump. For isolating equipment Apex Engineering Products

Corporation offers a complete pump line including the PumpMaster 115v (illustrated below), which is utilized to clean units with less than 50 gallons of total volume. Please visit our website www.ApexEngineeringProducts.com for a complete description of our available pumping systems.

PumpMaster 115v



- 3/4" seal-less magnetic drive pump
- maximum flow rate is 4.5 gpm
- 12 gallon HDPE open head bucket
- (2) lengths of 10' hose



RYDLYME is available in the following container sizes:

- 1 gallon jug
- 4 gallon case
- 5 gallon jug
- 30 gallon drum
- 55 gallon drum
- 330 gallon tote

Closed Circuit Cooling System

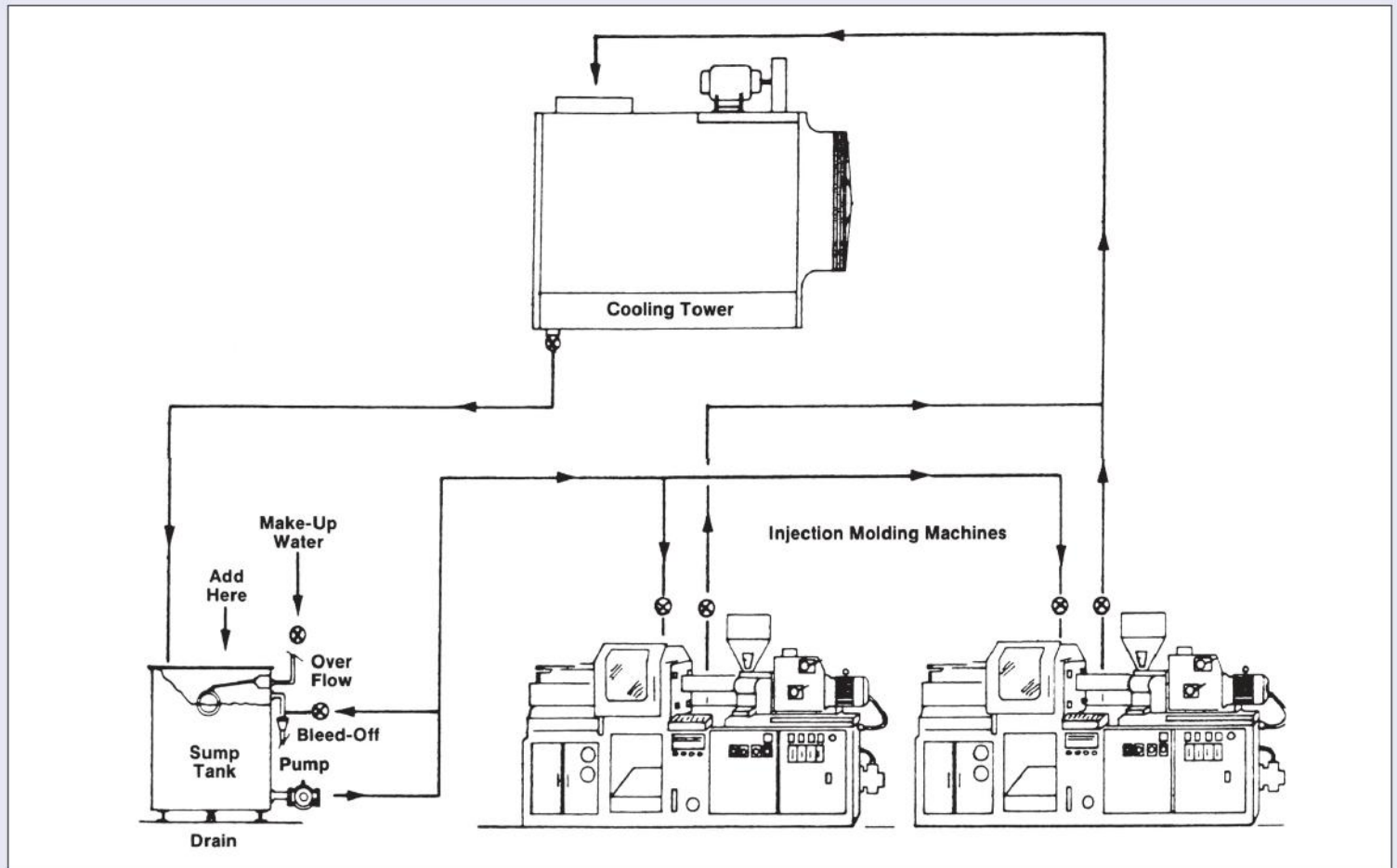

Cleaning of closed circuit water cooling systems is most usually accomplished while the water cooled equipment is on line and without the necessity of a shutdown.

Temperature Control Unit

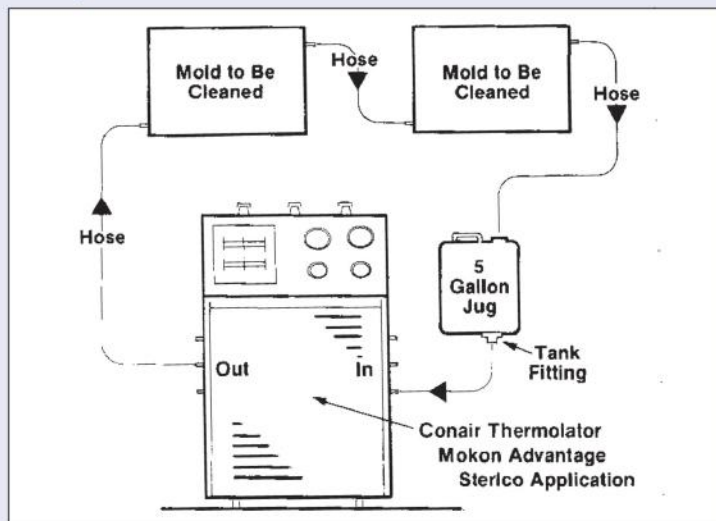

Support equipment, such as chillers, exchangers, temperature controllers and cooling towers are a vital part of your operation and can only afford you efficient operation when kept clean of water scale, lime and rust deposits.

Call today and speak to one of our experienced technicians for more detailed instructions on cleaning your water operated equipment.

Heat Exchangers

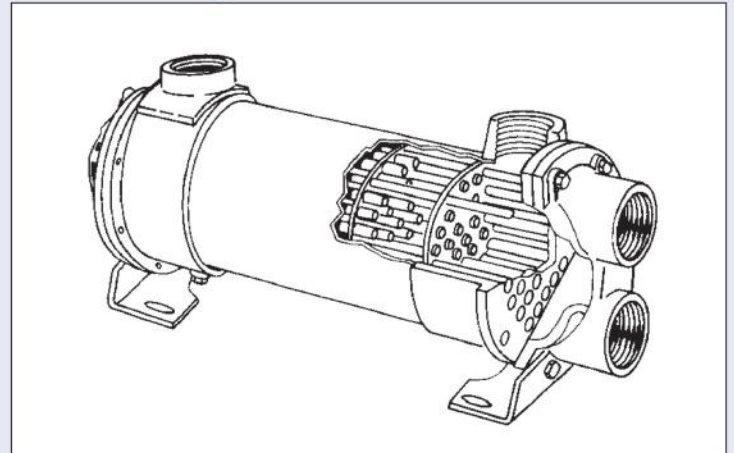

Any type of water cooled heat exchanger can usually be cleaned with **RYDLYME**. Hydraulic oil coolers that become fouled with water scale, lime and rust deposits will eventually cause a shutdown of expensive production equipment.

Periodic **RYDLYME** cleaning of your hydraulic oil coolers will keep this and other equipment operating efficiently.

RYDLYME is our solution to your problems.



RYDLYME gets rid of lime . . . This scientific solution chemically dissolves all water scale, lime and rust deposits as found in any type of water heated, cooled or operated equipment, without dismantling the equipment. **RYDLYME** restores original operating efficiency to your processing equipment when loss of efficiency is due to water scale, lime or rust deposits. Simply use **RYDLYME** on scaled equipment according to detailed, step by step instructions that are available upon request.

RYDLYME is very fast acting, and most of your applications can be cleaned in a matter of hours. **RYDLYME** will dissolve about two (2) pounds of water scale per gallon. Only **RYDLYME** does it so safely, simply, rapidly and economically.

Plastic Industry Applications

- Heat Exchangers
- Hydraulic Oil Coolers
- Water Cooled Chillers
- Water Cooling Towers
- Water Cooled Air Compressors
- Heater Bands
- System Piping
- Channels in Molds
- Valves and other parts
- Temperature Controllers

RYDLYME dissolves
water scale . . . lime . . . rust

2/11 Blaikie Street, Myaree WA 6154



(08) 9333 0777

www.rydlyme.com.au

6/17 Printed in U.S.A. ©Apex Engineering Products Corporation

RYDLYME is registered in the United States Patent and Trademark Office.



An ISO 9001 Certified Company
Certified to NSF/ANSI 60

